

Why Planar Magnetics are Ideal for Harsh Environments

Jim Marinos

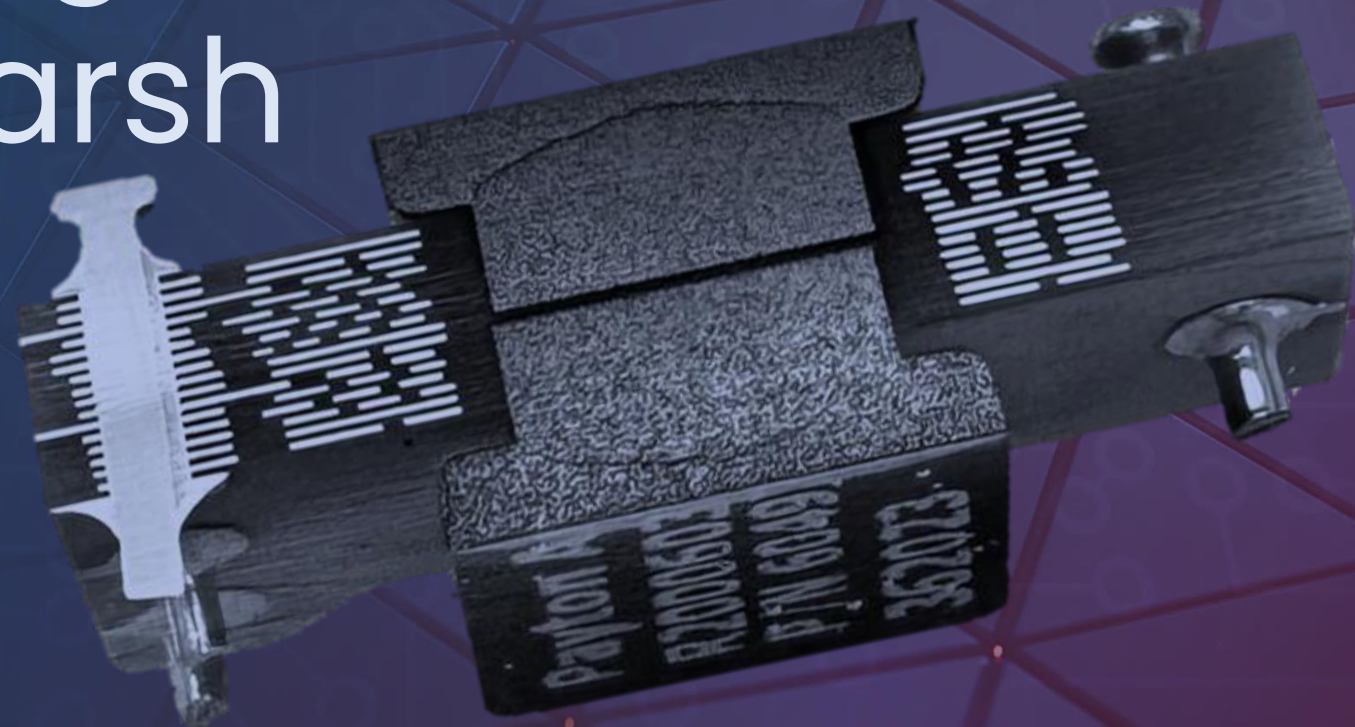

Who Is Payton

Established in 1987

Design and Manufacture of
Planar Magnetics.

Custom Designs
from few watts to 300kWatts

Designs Centers in the
USA, UK and Israel

US location is ITAR register
and 100% DOD projects

Why Planar for Space

- Reduced Size and Weight
- High Reliability & Repeatability based on few parts
- Simple Construction
- High efficiency up to 5Mhz
- Thermal management system, conduction cooling
- Screening per EEE-INST-002, Mil-Std-981 & MIL-STD-1580
- Partial Discharge designs up to 20kVrms with detection level to 1pC

Key Planar Points

Simple Construction



Build in Layers
High reliability
and repeatability



Easy to control
The electrical
parameters such as
leakage and capacitance



Simple Construction

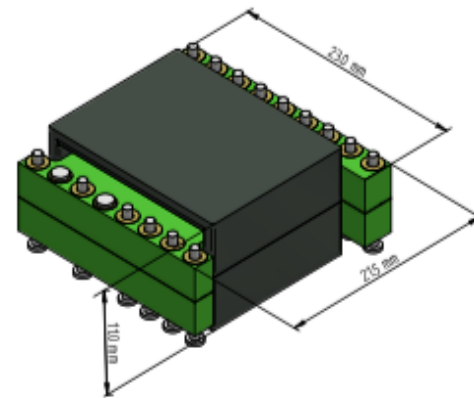
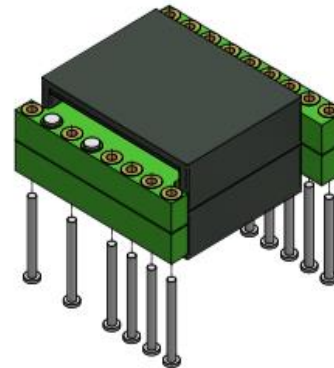
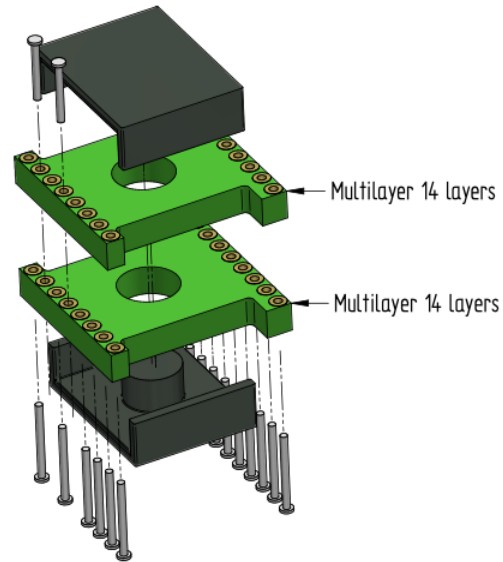
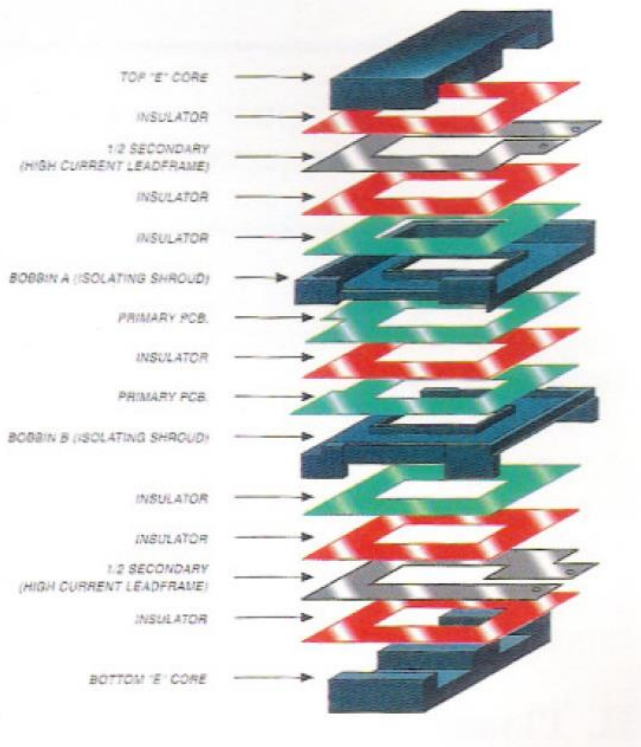

ELECTRICAL DIAGRAM

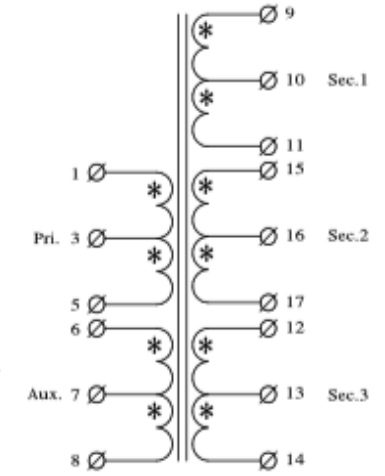

Payton Magnetic Planars

Size • Weight • Reliability • Producibility • Efficiency • Cooling



TRADITIONAL MAGNETICS

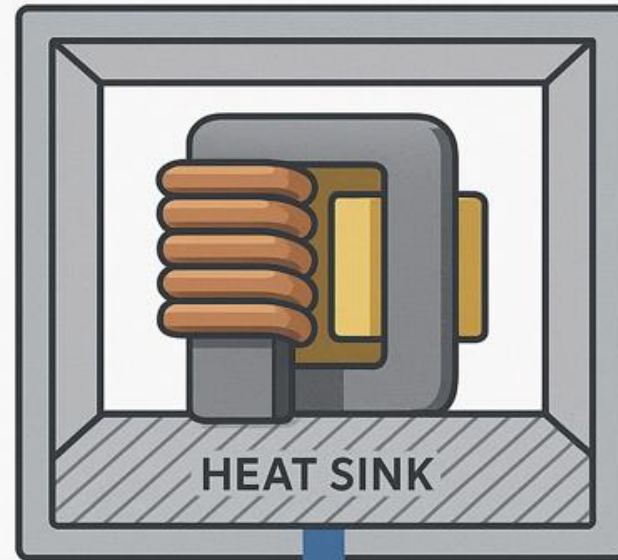

conduction
cooling

PLANAR MAGNETICS

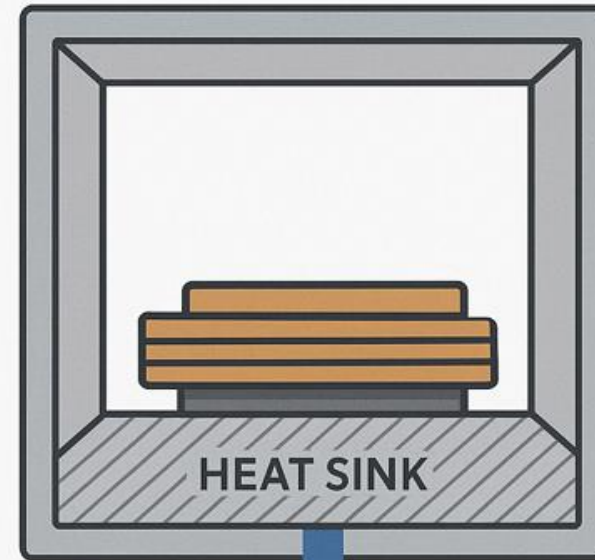

conduction
cooling

What makes a reliable Planar Design

1. Material Selection
2. Thermal Management
3. Mechanical Robustness
4. Electrical Integrity
5. Manufacturability
6. MIL-SPEC compliance

A reliable planar design balances performance with rugged construction. It's not just about layout. It's about selecting the right materials and ensuring robust thermal paths, maintaining mechanical stability and designing for consistent, repeatable manufacturing.

Proper derating and cooling is the key to the MTBF

$$\lambda_p = \lambda_b * \pi_T * \pi_Q * \pi_E \quad \text{Failure Rate / } 10^6 \text{ Hours}$$

Base Failure Rate for Transformer - λ_b is 0.049 (F/10⁶) for power over 300Watts.

Temperature Factor - π_T for a hot spot of 130C is 3.1

The Quality Factor - π_Q for a MIL-SPEC type of transformer is 1

The Environment Factor - π_E for GM is 12. π_E can vary from 0.50 for SF (Space, Flight) to 610 for CL (Cannon, Launch)

So the λ_p for this transformer is 1.8 Total failures per million hours (FPMH)

The MTBF then will be $1/\lambda_p = 555,000$ Hours for a 130C hot spot transformer working in a Ground Mobile environment.

Management Of Parasitics In Planar Magnetics

1. Minimizing Leakage Inductance
2. Managing Interwinding Capacitance
3. Controlled Impedance Design
4. Parasitic Modeling and Simulation
5. Layout of the windings
6. MIL-SPEC compliance

Managing parasitics in planar magnetics is *critical* to ensure efficiency, EMI performance, and reliability—especially in high-frequency and high-reliability environments like aerospace. The key parasitics are leakage inductance and interwinding capacitance, and both can be managed through careful design choices

Real operating condition test system – Example

Test example for no load operation to test core losses showing asymmetrical heating a few minutes after start of operation due to airgap issues.

Following test, we have modified sample and retested to see issue solved.

Adding cooling clasp to this sample gave us the required temperature rise stabilization as seen on the right

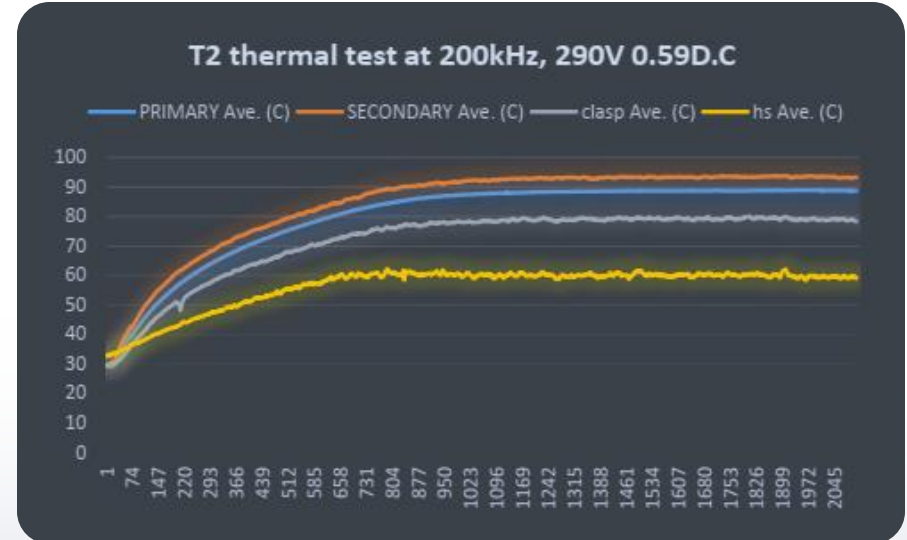
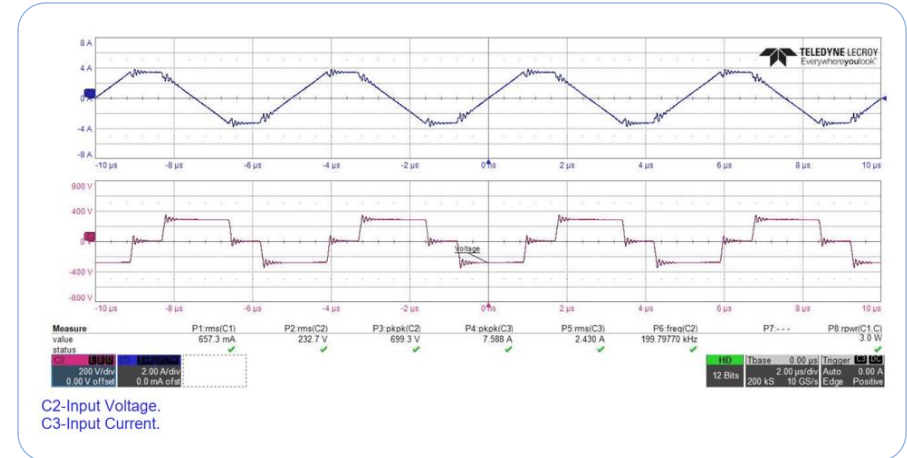
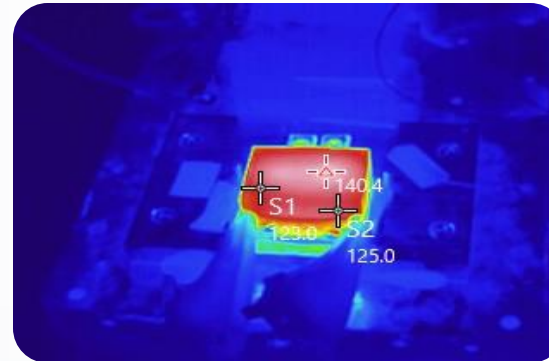
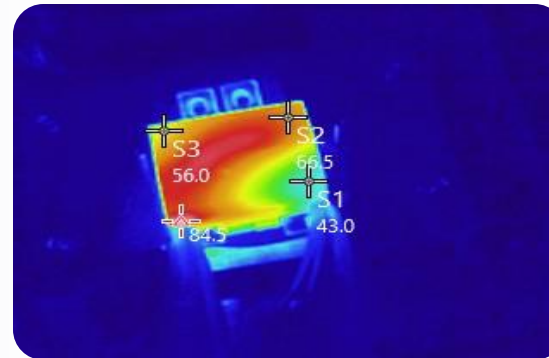

Simulation Verification Of Design – Ansys

Integrated design flux distribution

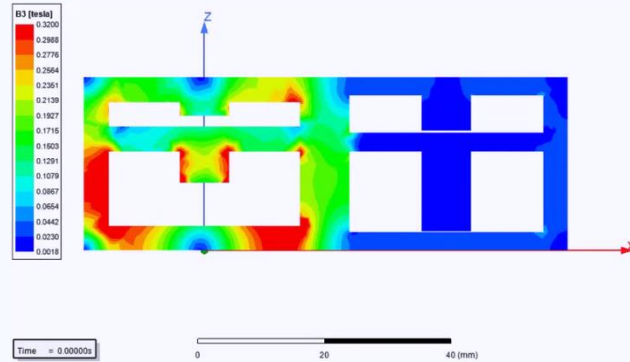

Thermal check

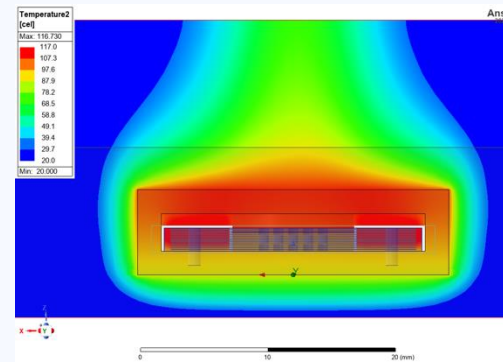

Impedance analysis

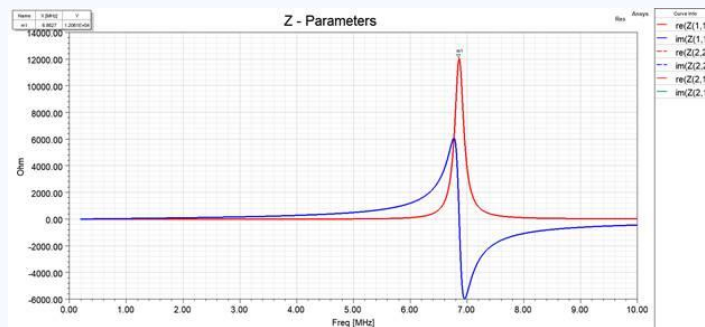

Electric fields – PD risk

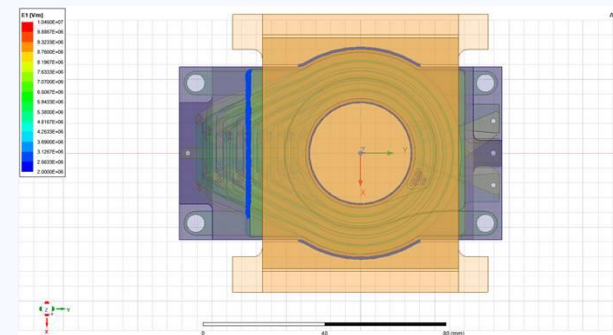

DPA per MIL-STD-1580C, Req 15.1 & MIL-STD-981C, B, B

- External PMA
- Radiographic
- Internal Visual
- Internal PMA

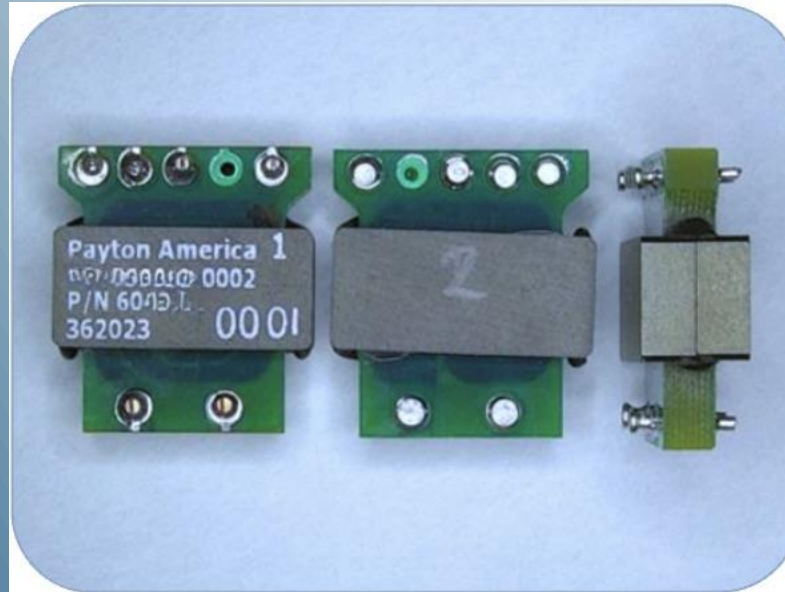

External Prohibited Material Analysis Example

7328-019-01B_PN 60497
Transformer - External PMA

03/28/2024

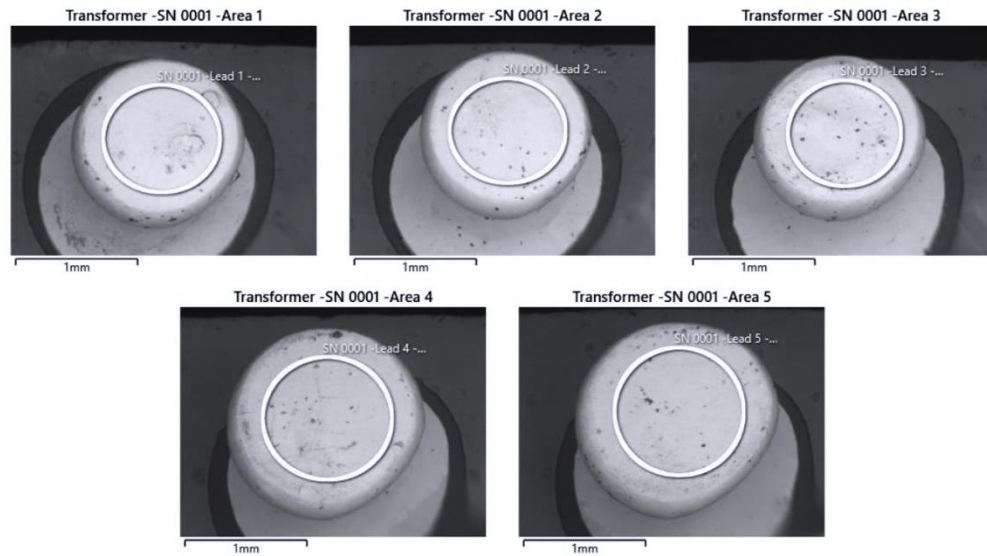

Spectrum Label	SN 0001 -Lead 1 - Side 1 -Solder	SN 0001 -Lead 2 - Side 1 -Solder	SN 0001 -Lead 3 - Side 1 -Solder	SN 0001 -Lead 4 - Side 2 -Solder	SN 0001 -Lead 5 - Side 2 -Solder
Sn	80.18	88.49	82.98	76.44	53.48
Pb	19.82	11.51	17.02	23.56	46.52
Total	100.00	100.00	100.00	100.00	100.00

Statistics	Sn	Pb
Max	88.49	46.52
Min	53.48	11.51
Average	76.32	23.68
Standard Deviation	13.50	13.50

Qualification Plan

Group Number	Tests	Paragraphs
GROUP I (2 Samples)	Solderability	3.5; 4.7.2
GROUP II (2 Samples)	Dielectric withstanding voltage at atmospheric pressure	3.11; 4.7.9.1
	Dielectric withstanding voltage at barometric pressure	3.11; 4.7.9.2
	Insulation resistance	3.13a; 4.7.11
	Electrical characteristics	3.14; 4.7.12
GROUP III (6 Samples)	Corona discharge	3.16; 4.7.14
	Thermal shock	3.7.1; 4.7.4.1
	Winding continuity	3.20; 4.7.18
	Vibration	3.18; 4.7.16
	Shock	3.19; 4.7.17
	Dielectric withstanding voltage at reduced voltage	3.11; 4.7.9
	Insulation resistance	3.13b; 4.7.11
	Winding continuity	3.20; 4.7.18
	External Visual & Dimensions Inspection	3.24; 4.7; 1.1.1
	Electrical characteristics	3.14; 4.7.12
GROUP IV (2 Samples)	Life	3.26; 4.7.23
	Dielectric withstanding voltage at reduced voltage	3.11; 4.7.9
	Insulation resistance	3.13c; 4.7.11
	External Visual & Dimensions Inspection	3.24; 4.7; 1.1.1
	Electrical characteristics	3.14; 4.7.23
DPA	DPA	MIL-STD-1580C, Requirement 15.1

Qualification Plan

Qualification plan of [REDACTED] Rev. C

PAYTON P/N 60497

Qual Quantity - 15 pcs
Date Code: 362023

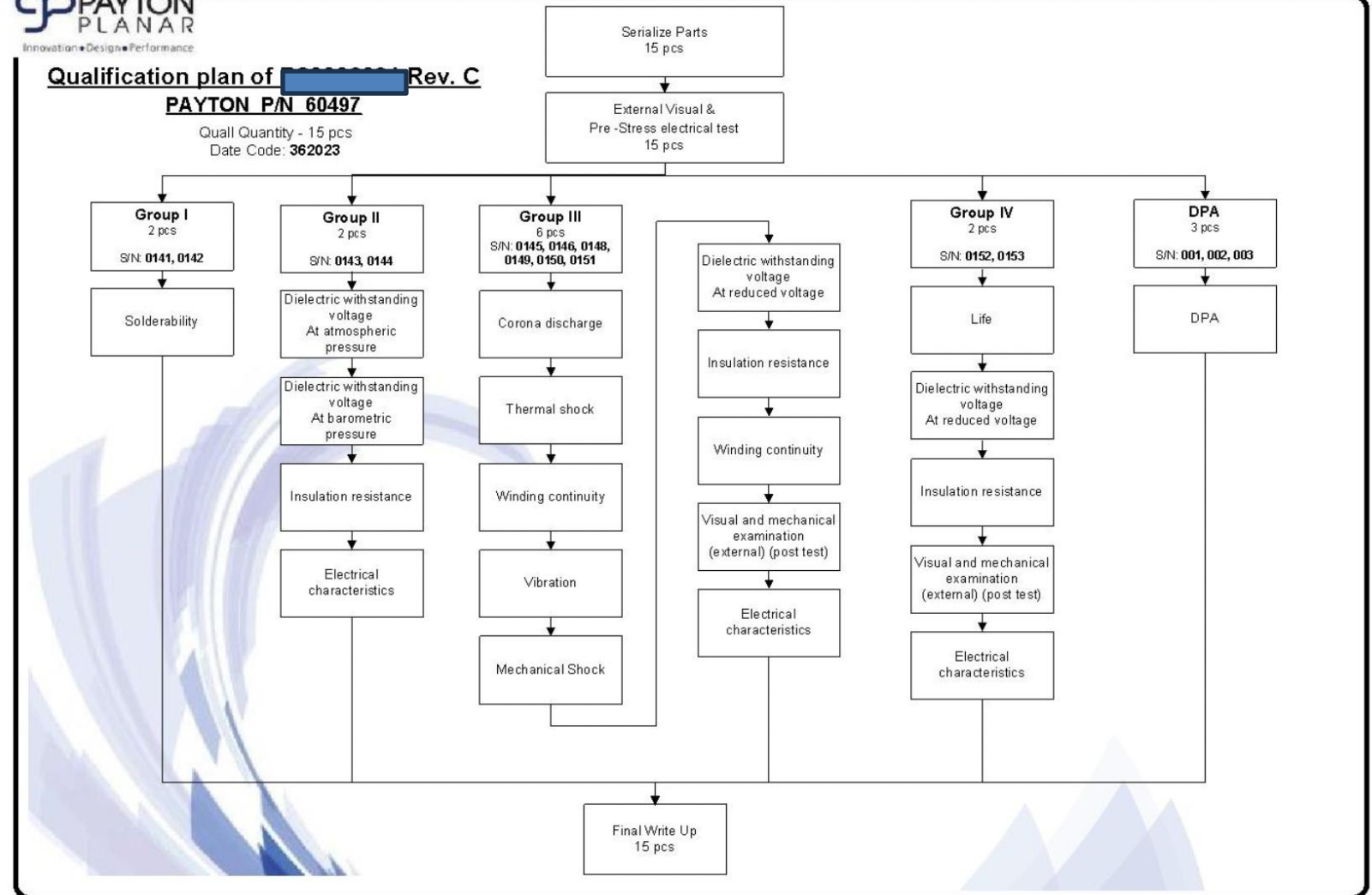

Executive Summary

Fifteen (15) serialized transformers 60497-2 (DC: 362023 S/N 001-003,0141-0146, 0148-0153) were received for Environmental testing per MIL-PRF-27G, MIL-STD-202H, J-STD-002D, MIL-STD-1580C and Payton Test File (60497-2). The following table summarizes the tests that have been performed.

Group Number	Tests	TESTED	Sample Size	Pass/Fail	Report
GROUP I (2 Samples)	Solderability	02/04/2024	2	Pass	60497-362023-1-1
GROUP II (2 Samples)	Dielectric withstanding voltage at atmospheric pressure	04/01/2024	2	Pass	60497-362023-1-2
	Dielectric withstanding voltage at barometric pressure	04/01/2024		Pass	
	Insulation resistance	04/01/2024		Pass	
	Electrical characteristics	04/02/2024		Pass	
GROUP III (6 Samples)	Corona discharge	12/17/2023	6	Pass	60497-362023-1-3
	Thermal shock	12/18/2023		Pass	
	Winding continuity	12/19/2023		Pass	
	Vibration	03/04-06/2024		Pass	
	Shock	03/06-07/2024		Pass	
	Dielectric withstanding voltage at reduced voltage	03/10/2024		Pass	
	Insulation resistance	03/10/2024		Pass	
	Winding continuity	03/10/2024		Pass	
	External Visual & Dimensions Inspection	03/10/2024		Pass	
	Electrical characteristics	03/10/2024		Pass	
GROUP IV (2 Samples)	Life	12/14/2023-03/10/2024	2	Pass	60497-362023-1-4
	Dielectric withstanding voltage at reduced voltage	03/10/2024		Pass	
	Insulation resistance	03/10/2024		Pass	
	External Visual & Dimensions Inspection	03/10/2024		Pass	
	Electrical characteristics	03/10/2024		Pass	
DPA	DPA	03/29/2024-04/01/2024	3	Pass	7328-019-01B

Vibration

Graph 4 Z-Axis Vibration Performance

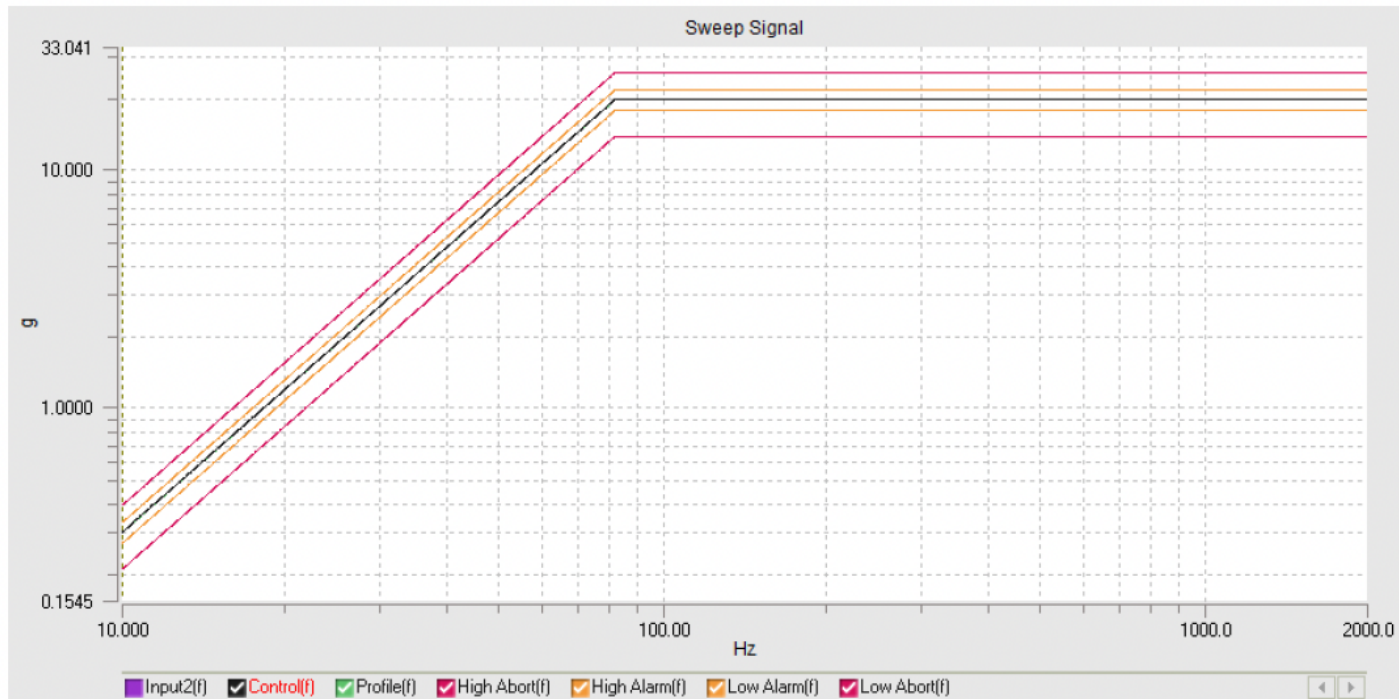

**Pic. 10 Z-Axis
Vibration Test**



Parameter Name	Parameter Value
Axes	3 (X,Y,Z)
Frequency Range	10-2000-10 Hz
Duration per Axis	4 hrs.
Max Vibration Level	20 g-pk
Number of Sweep Cycles	24
Sweep Rate	10 min/sweep

Mechanical Shock

Graph 5 X-Axis Shock Performance

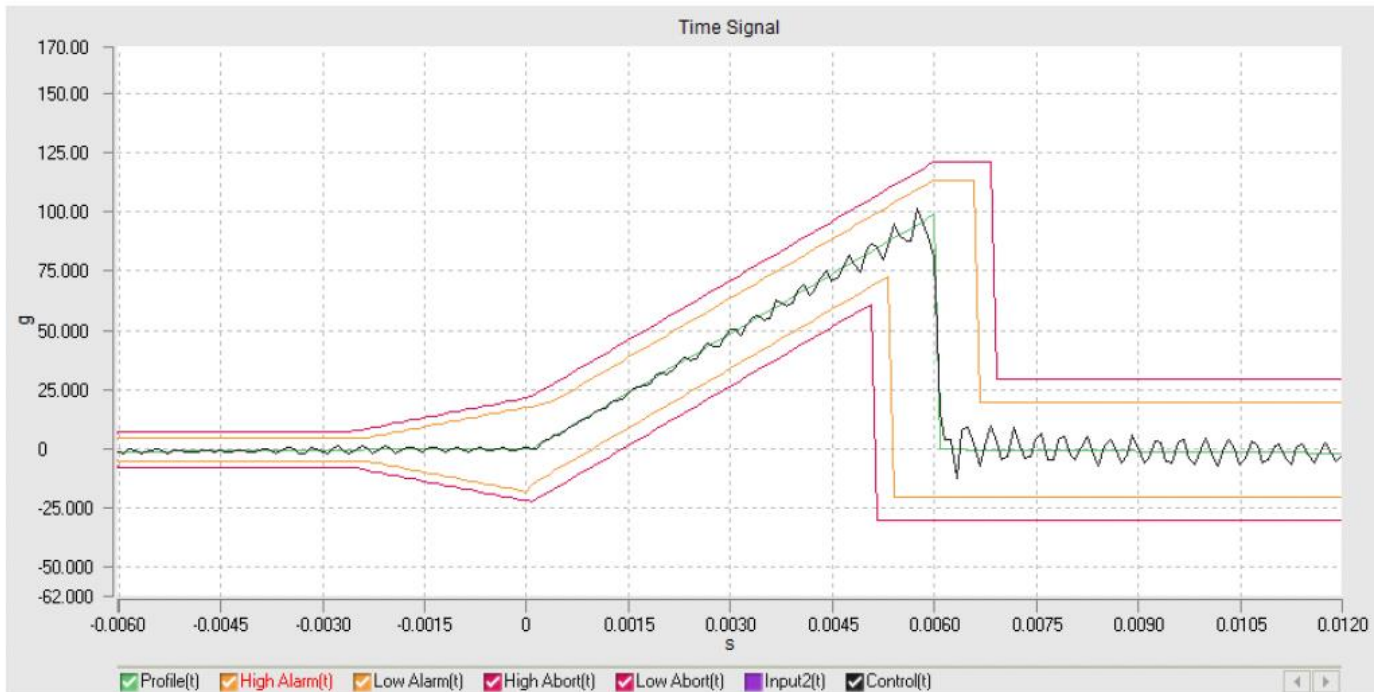

Pic. 11 X-Axis Shock Test

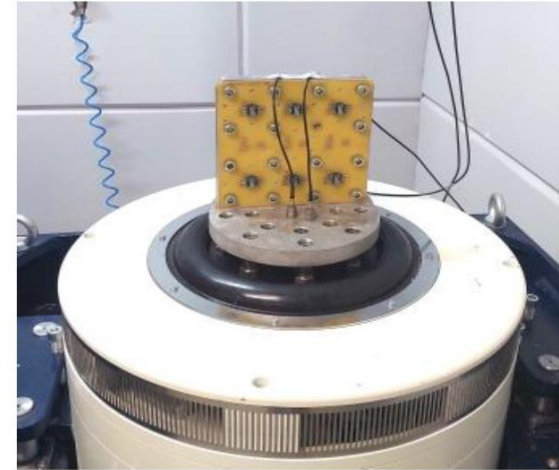

Parameter Name	Parameter Value
Axes	3 ($\pm X, \pm Y, \pm Z$)
Shock Form	Sawtooth
Shocks per Axis	6 (3 each direction)
Total No. Shocks	18
Pulse Duration	6 msec
Shock Amplitude	100 g

Life

Part Number	60497 Rev.00
Total output power of power supply	10 Watt DC (5V/1.8A dc 13-15V/0.1A dc)
Life Test Load Conditions	
Input Wave	Full Sinus
Frequency	200kHz
Input Voltage	12.8 Vrms
Sec. 1 (7-9)	
Prim. to Sec. turn ratio	12:3
Secondary Voltage	3.2 Vrms
Max. Secondary Current	2.67 Arms
Secondary Power	8.54 VA Rms
Sec. 2 (4-5)	
Prim. to Sec. turn ratio	12:8
Secondary Voltage	8.53 Vrms
Max. Secondary Current	0.2 Arms
Secondary Power	1.71 VA Rms
Total output (all secondaries)	10.25 VA Rms

Pic.3

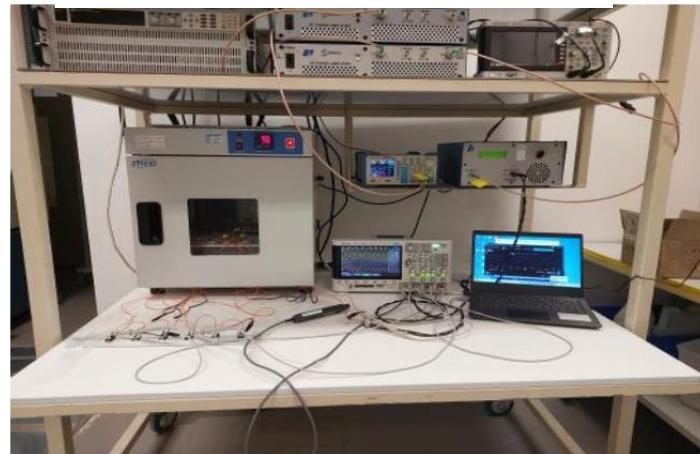

Pic.4

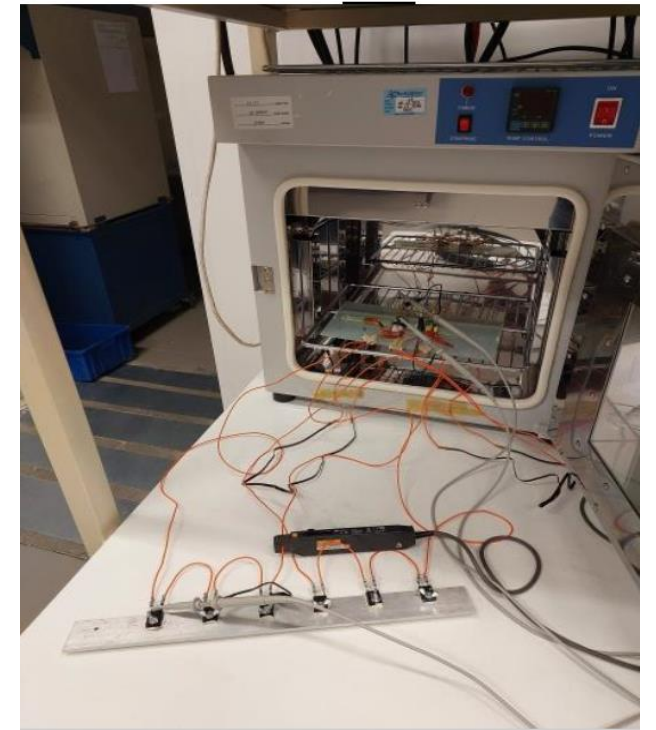

Lifetime Prediction Of Planar Magnetics For Harsh Environments

Inductance



Ferrite glue



Multilayer Boards

Laminates and Prepregs,
Tg, Td, Thermal, Moisture



Partial discharge



Ferrite Cores MnZn





Thank You

Jim@paytongroup.com

www.paytongroup.com