

# UCC3895 Phase Shift PWM Controller EVM Kit Setup and Usage

Power Supply Control Products

## 1 Introduction

The UCC3895 evaluation board is a 48-V input dc-to-dc converter providing 3.3 V at 15 A. It also provides 1500-V isolation between the primary and secondary portions of the circuit. This user's guide provides the test setup and component details needed to evaluate the UCC3895 evaluation board, along with some operational waveforms.

This evaluation board uses the UCC3895 advanced phase shift PWM controller to implement control of a full-bridge power stage by phase-shifting the switching of one half-bridge with respect to the other half-bridge. The circuit operates at a fixed frequency using peak current mode control, yet promotes zero voltage switching (ZVS) over a significant portion of the converter load range. ZVS is achieved by using the converter's parasitic capacitance, leakage inductance, and a small discrete inductor in series with the primary winding. Additional information on the full-bridge phase-shifting technique and the current-doubler rectifier can be found in references [1] - [3].

This evaluation board is intended to provide an introduction to phase-shifting full-bridge power converters at a safe input voltage and power level. It is recognized that 50 W is below the typical application level of a full-bridge power supply. This topology can be used from a few hundred watts to several kilowatts with the same basic circuit configuration.

### 1.1 Features

The UCC3895 phase-shift PWM controller includes:

- Programmable output turnon delay
- Adaptive delay set
- Bidirectional oscillator synchronization
- Capability for voltage mode or current mode control
- Programmable softstart and chip disable via a single pin
- 0% to 100% duty cycle control
- 7-MHz error amplifier
- Operation to 1 MHz
- Low active current consumption (5 mA typical @ 500 kHz)
- Very low current consumption during undervoltage lockout (150  $\mu$ A typical)

## 1.2 Description

The UCC3895 provides the logic and drive signals to control the full-bridge phase shifted power supply, maintaining the functionality of the UC3875/6/7/8 and the UC3879. However, the UCC3895 improves on the previous phase shift controller families by adding features such as enhanced control logic, adaptive delay set, and shutdown capability. Since it is built in BCDMOS, it operates with dramatically less supply current than its bipolar counterparts.

## 2 Schematic

A schematic of the UCC3895 evaluation board is shown in Figure 1. Terminal J2 is the input voltage source, J3 takes an external bias supply, and the output is taken from J1.

A quick overview of the primary circuitry on the left-hand portion of the schematic shows the full-bridge power section in the center comprised of MOFETs Q1-Q4. The control signals are provided by U1, the UCC3895, with its accompanying circuitry. Current transformer T2 senses the primary current and provides information to the controller. PWM outputs OUTA-OUTD are buffered through driver ICs, U5 and U7, and connected to the power switching devices through gate drive transformers T3 and T4. Power is delivered to the secondary through power transformer T1.

The secondary portion of the circuit is shown on the right-hand side, and is fed from the single secondary winding of T1. This rectifier is comprised of diodes D9 and D10, output chokes L2 and L3, and output capacitors C15 and C16. The output voltage is sensed through the R17-R18 divider, and a TL431 is used as an error amplifier to feed back an error signal through optocoupler U3. The onboard amplifier in the UCC3895 is configured as a voltage follower in this application.

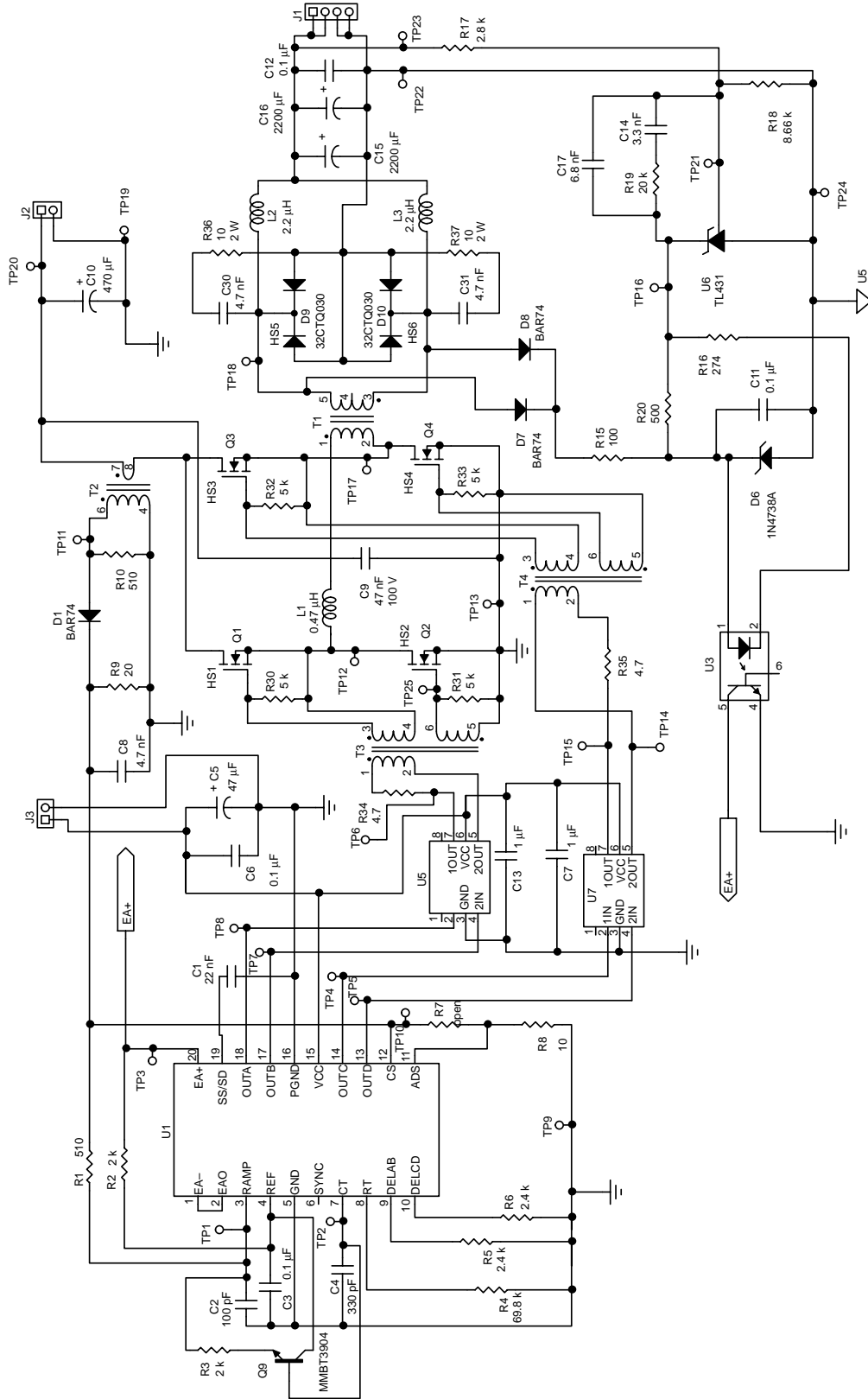
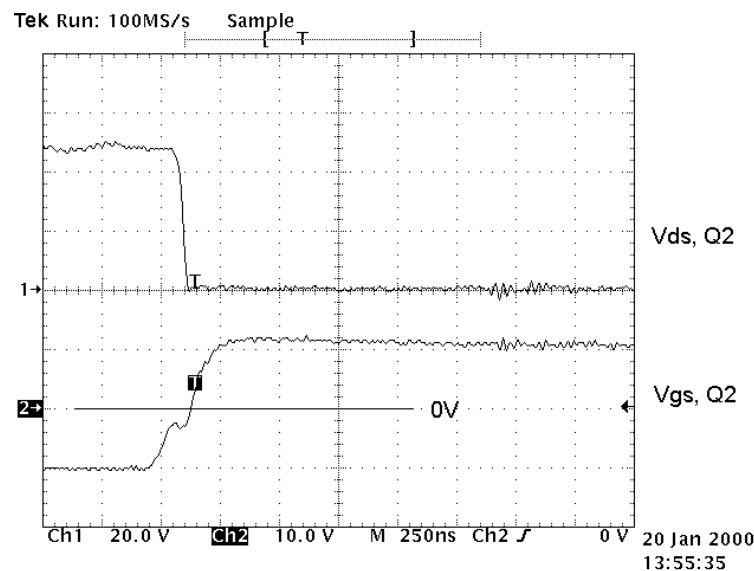

Figure 1. Evaluation Board Schematic

UDG-99127

### 3 Circuit performance

This circuit has been built and evaluated in the laboratory. Figure 2 shows the pertinent waveforms to demonstrate zero voltage switching at the rated load of 15 A. Note that the gate drive swings positive and negative 10 V around ground, and is still negative when the drain-source voltage of Q2 reaches 0 V. Then, the gate-source voltage goes positive to turn Q2 ON. At loads below 10 A, the circuit loses ZVS. References [1] and [2] provide much detail on the component relationships that affect the ZVS operation. Note that the plateau visible in the  $V_{GS, Q2}$  waveform in Figure 2 is from the turnoff of Q1, the other MOSFET driven by the same gate drive transformer.



**Figure 2. Zero Voltage Switching ZVS of Q2**

At a load current of 15 A, the circuit has an efficiency of 76.8% with Schottky rectifiers. These rectifiers were used to keep the complexity of this EVM low in order to simplify the evaluation of the UCC3895 control IC. In the lab, each Schottky was replaced with a single control-driven synchronous-rectifier (SR) MOSFET and the efficiency was measured to be 83% at 15 A. Multiple SR MOSFETs and suitably sized magnetics could be used to extend the power range to hundreds of watts with good efficiency. Note that the full bridge does suffer a penalty due to the necessity of driving four devices; this is mitigated as the power level increases.

The study of the EVM efficiency led the author to find that the primary-side gate-drive transformers are being pushed to the limits of acceptable operation. An application at 200-kHz with a constant 50% duty cycle causes the transformers to run at the edge of a soft saturation characteristic in normal operation. This causes some undesired losses in the core material and drivers ICs. This component would be effective at 400 kHz–500 kHz but should be replaced in this 200 kHz application. Possible solutions include increasing the core cross-sectional area in the gate-drive transformer or replacing the gatedrive transformer and driver IC with a high-speed half-bridge driver IC.

## 4 Test points

Twenty-five testpoints have been provided to monitor the significant voltage waveforms in the circuit. Their locations are given in Table 1.

### Test Point Designations and Locations

| TEST POINT | LOCATION                           |
|------------|------------------------------------|
| TP1        | U1 pin 3, RAMP                     |
| TP2        | U1 pin 7, C <sub>T</sub>           |
| TP3        | U1 pin 20, EA+                     |
| TP4        | U1 pin 14, OUTC                    |
| TP5        | U1 pin 13, OUTD                    |
| TP6        | U5 pin 7, driverA                  |
| TP7        | U1 pin 17, OUTB                    |
| TP8        | U1 pin 18, OUTA                    |
| TP9        | U1 pin 5, control GND              |
| TP10       | U1 pin 12, CS                      |
| TP11       | T2 pin 6, CT signal                |
| TP12       | Q1 source, Q2 drain                |
| TP13       | Power GND                          |
| TP14       | U7 pin 5, driverD                  |
| TP15       | U7 pin 7, driverC                  |
| TP16       | U6 pin 3, TL431 cathode            |
| TP17       | Q3 source, Q4 drain                |
| TP18       | T1 pin 5,<br>transformer secondary |
| TP19       | V <sub>IN</sub> (-)                |
| TP20       | V <sub>IN</sub> (+)                |
| TP21       | U6 pin 1,<br>TL431 reference       |
| TP22       | V <sub>OUT</sub> (-)               |
| TP23       | V <sub>OUT</sub> (+)               |
| TP24       | U6 pin 2,<br>secondary common      |
| TP25       | Q2, gate                           |

## 5 Test setup

Figure 2 shows the basic lab configuration needed to power up the UCC3895 EVM.

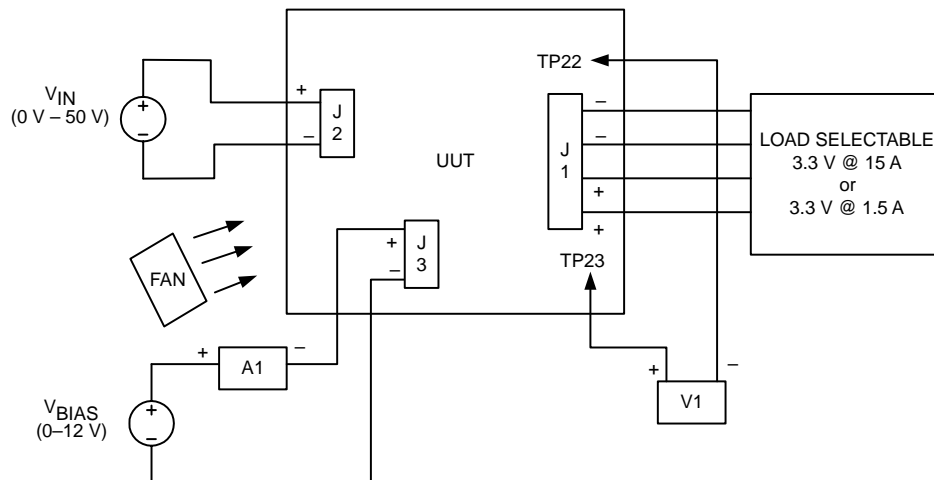

Figure 3. Basic Lab Configuration

### 5.1 Logic Power Required ( $V_{BIAS}$ )

An external bias supply should be applied to J3 to bring the control circuitry alive before input power is applied.  $V_{BIAS}$  should be raised above the UVLO threshold (11 V) of the UC3895, and then set at 10.5 V for optimal efficiency. With the J3 bias applied the control and switching circuitry can be checked from the UCC3895 outputs out to the gates of the switching MOSFETs Q1–Q4.

### 5.2 Input Source ( $V_{IN}$ )

The input voltage source applied to J2 should be capable of delivering 2 A of current to allow operation at full load. With an input of 48 V and an efficiency of approximately 75% the evaluation board draws 1.4 A with a 50-W load. Wire of 22 gauge (or larger wire diameter) can be used to make the input connections.

### 5.3 Output Load

The output connections to J1 should be made with (2) parallel 16 gauge wires, or larger, for both the + output and the return to the load. Paralleled resistors or an electronic load can be used, with the latter enabling easier output current measurements. Using (2) parallel 16 gauge wires to run 2 feet to a load introduces a voltage drop over 100 mV, so remember to make all output voltage measurements on the PCB at TP22 and TP23. This is indicated by V1 in the diagram above.

### 5.4 Fan

Most power converters have power components that operate at temperatures that are high enough to cause burns if handled improperly. This evaluation board makes components accessible to allow probing of the circuit waveforms. Therefore, a small fan capable of 20–30 cfm is recommended to reduce the component temperatures with a 50-W output.

## 6 UCC3895-EVM part descriptions

Table 2 shows a listing of the materials used in the UCC3895 evaluation board. Specific manufacturers are not given for the generic components.

**UCC3895 Bill of Materials**

|                | Reference        | Qty        | Description                                   | Manufacturer            | Part Number    |
|----------------|------------------|------------|---|-------------------------|----------------|
| PCB            | B1               | 1          | 2-Layer, 2-oz, 8"(L)x5"(W)x0.062"(T)          |                         | UCC3895 Rev. B |
| Capacitor      | C1               | 1          | 22 nF, 50 V, 10%, X7R, ceramic                | Panasonic               | ECU-V1H223K BX |
|                | C2               | 1          | 100 pF, 50 V, 5% NPO, ceramic                 | Panasonic               | ECU-V1H101JCG  |
|                | C3, C6, C11, C12 | 4          | 0.1 $\mu$ F, 50 V, 10%, X7R, ceramic          | Panasonic               | ECJ-2YB1H104K  |
|                | C4               | 1          | 330 pF, 50 V, 10%, X7R, ceramic               | Panasonic               | ECU-V1H331KBN  |
|                | C5               | 1          | 47 $\mu$ F, 25 V, 20%, aluminum electrolytic  | Panasonic               | ECE-A1EGE470   |
|                | C7, C13          | 2          | 1 $\mu$ F, 25 V, 10%, X7R, ceramic            | Panasonic               | ECJ-3YB1E105K  |
|                | C8, C30, C31     | 3          | 4.7 nF, 50 V, 10%, X7R, ceramic               | Panasonic               | ECU-V1H472K BG |
|                | C9               | 1          | 47 nF, 100 V, 10%, X7R, ceramic               | Panasonic               | ECJ-3YB2A473K  |
|                | C10              | 1          | 470 $\mu$ F, 63 V, 20%, aluminum electrolytic | Panasonic               | EEU-FA1J471L   |
|                | C14              | 1          | 3.3 nF, 50 V, 10%, X7R, ceramic               | Panasonic               | ECU-V1H332KBN  |
|                | C15, D16         | 2          | 2200 $\mu$ F, 6.3 V, 20%                      | Panasonic               | ECA-0JFQ222    |
|                | C17              | 1          | 6.8 nF, 50 V, 10%, X7R, ceramic               | Panasonic               | ECU-V1H682K BG |
|                | Diode            | D1, D7, D8 | 3   | 0.15 A, 50 V, UF signal | Zetex          |
| D6             |                  | 1          | 8.2 V, 0.35 W, zener                          | Zetex                   | BZX84C8V2      |
| D9, D10        |                  | 2          | 30 A, 30 V, schottky                          | International Rectifier | 32CTQ030       |
| Heatsink       | HS1-4            | 4          | Q1-Q4   | Aavid                   | 592502B03400   |
|                | HS5, HS6         | 2          | D9, D10                                       | THM                     | THM6298B       |
| Terminal block | J1               | 1          | 4-pin, 16 A, 5 mm                             | OST                     | ED104/4DS      |
|                | J2               | 1          | 2-pin, 6 A, 5 mm                              | OST                     | ED350/2        |
| Header         | J3               | 1          | Single row, 2-pin, 0.1"                       | Molex Waldom            | 22-03-2021     |
| Inductor       | L1               | 1          | 0.47 $\mu$ H, 4 A <sub>RMS</sub>              | Coiltronics             | CTX16-14847    |
|                | L2, L3           | 2          | 2.2 $\mu$ H, 25 A <sub>RMS</sub>              | Coiltronics             | HC2-2R2        |
| MOSFET         | Q1, Q2, Q3, Q4   | 4          | N-ch, 100 V, 0.058 $\Omega$                   | Motorola                | MTP33N10E      |
| Transistor     | Q9               | 1          | NPN, 40 V, 0.2 A                              | Zetex                   | FMMT2222       |
| Resistor       | R1, R10, R20     | 3          | 510 $\Omega$ , 0.1 W, 5%, surface mount       |                         | Generic        |
|                | R2, R3           | 2          | 2 k $\Omega$ , 0.1 W, 5%, surface mount       |                         | Generic        |
|                | R4               | 1          | 69.8 k $\Omega$ , 0.1 W, 5%, surface mount    |                         | Generic        |
|                | R5, H6           | 2          | 2.4 k $\Omega$ , 0.1 W, 5%, surface mount     |                         | Generic        |
|                | R7               |            | Not used                                      |                         | Generic        |
|                | R8               | 1          | 10 $\Omega$ , 0.1 W, 5%, surface mount        |                         | Generic        |
|                | R9               | 1          | 20 $\Omega$ , 0.1 W, 5%, surface mount        |                         | Generic        |
|                | R11              |            | Not used                                      |                         | Generic        |

| Description            | Reference             | Qty | Value/Type Number                          | Manufacturer     | Part Number    |
|------------------------|-----------------------|-----|--|------------------|----------------|
| Resistor               | R15                   | 1   | 100 $\Omega$ , 0.1 W, 5%, surface mount    |                  | Generic        |
|                        | R16                   | 1   | 274 $\Omega$ , 0.1 W, 5%, surface mount    |                  | Generic        |
|                        | R17                   | 1   | 2.8 k $\Omega$ , 0.1 W, 5%, surface mount  |                  | Generic        |
|                        | R18                   | 1   | 8.66 k $\Omega$ , 0.1 W, 5%, surface mount |                  | Generic        |
|                        | R19                   | 1   | 20 k $\Omega$ , 0.1 W, 5%, surface mount   |                  | Generic        |
|                        | R30, R31, R32,<br>R33 | 4   | 4.99 k $\Omega$ , 0.1 W, 5%, surface mount |                  | Generic        |
|                        | R34, H35              | 2   | 4.7 $\Omega$ , 1 W, 5%, surface mount      |                  |                |
|                        | R36, H37              | 2   | 10 $\Omega$ , 1 W, 5%, Axial               |                  |                |
| Power transformer      | T1                    | 1   |  | Payton           | P/N 9225 Rev C |
| Current transformer    | T2                    | 1   |  | GB International | 3448-G         |
| Gate drive transformer | T3,T4                 | 2   |  | GB International | 2094-MM        |
| Test points            | TP1-25                | 25  | White                                      | Keystone         | 5007           |
| IC                     | U1                    | 1   | Phase shift controller, SOIC-20            | Unitrode         | UCC3895DW      |
|                        | U5, U7                | 2   | Dual driver IC, DIP-8                      | TI               | TPS2812P       |
|                        | U6                    | 1   | Amp/reference, TO-92                       | TI               | TL431          |
|                        | U3                    | 1   | Optocoupler, DIP-6                         | Various          | CNY17-2        |

NOTES: 1. The values of these components are to be determined by the user in accordance with the application requirements.  
2. All resistors have tolerances of  $\pm 1\%$ .

## 7 Silkscreen and traces

Figures 4, 5, and 6 show the show the silkscreen and traces for the UCC3895 EVM.

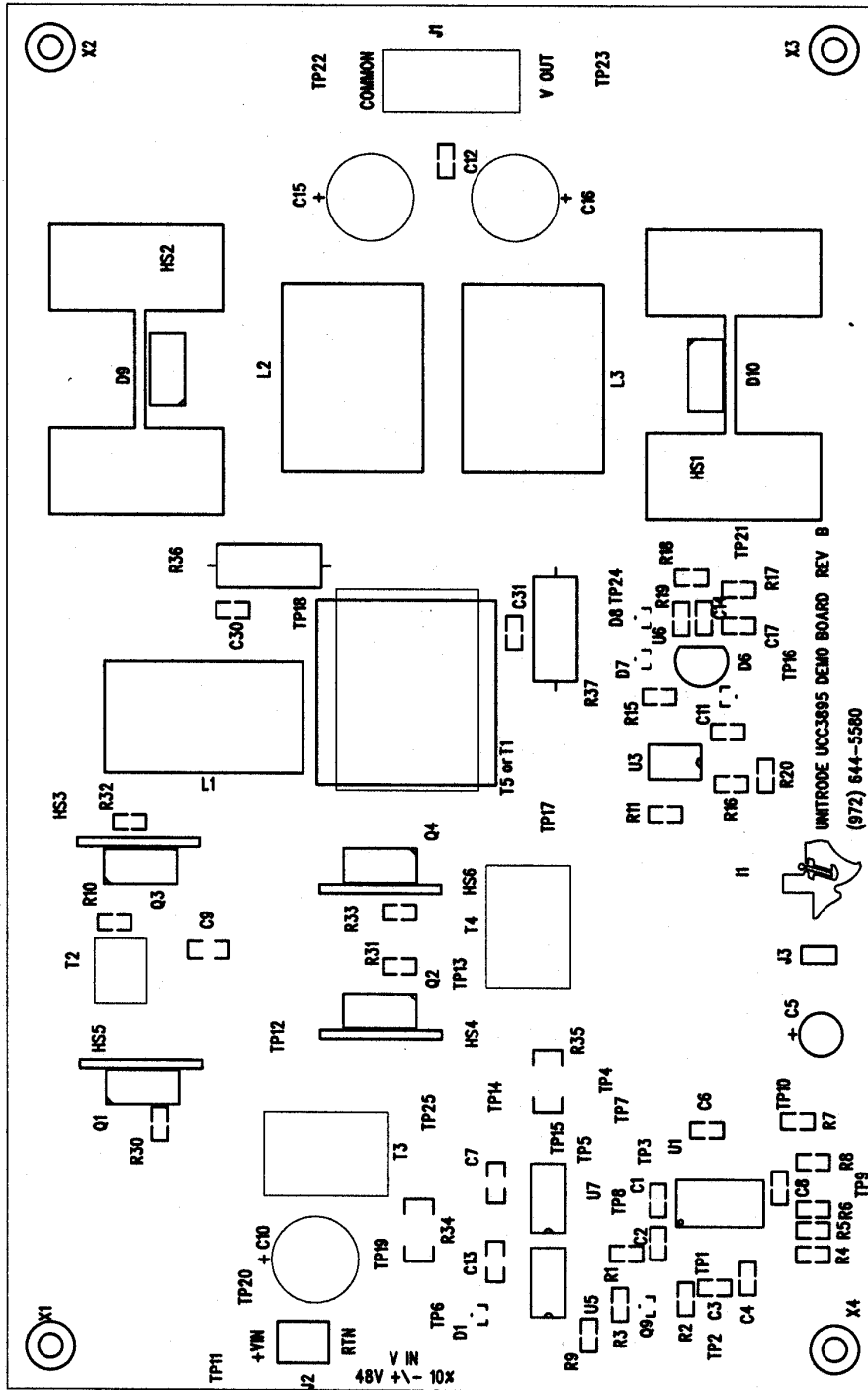

Figure 4. Silkscreen of the UCC3895

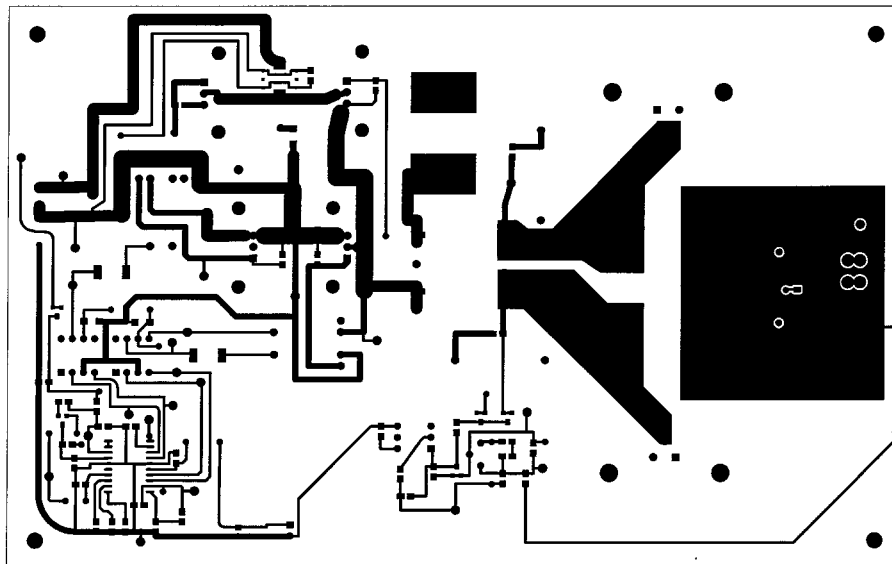

Figure 5. Top Trace of the UCC3895

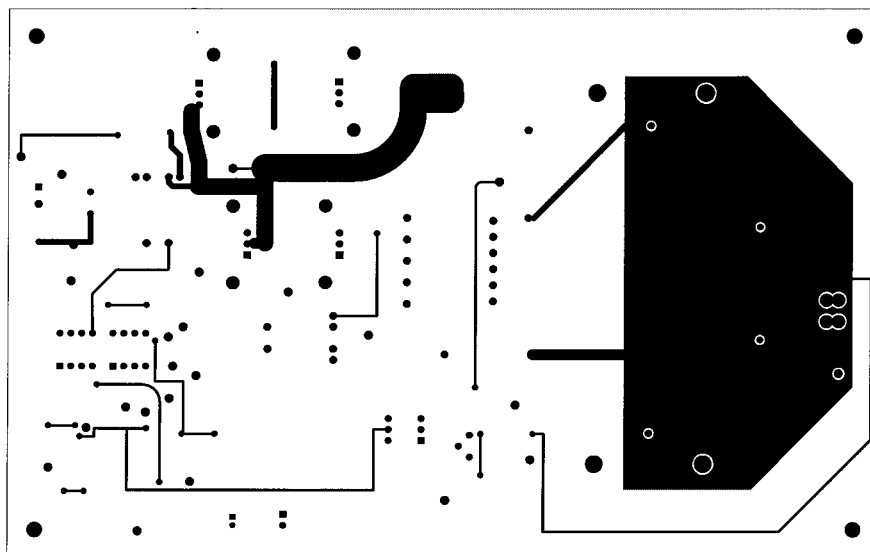

Figure 6. Bottom Trace of the UCC3895

## 8 References

- [1] Balogh, L. *Design Review: 100 W, 400 kHz, DC/DC Converter With Current Doubler Synchronous Rectification Achieves 92% Efficiency*, Topic 2, SEM-1100 Power Supply Design Seminar Manual, Unitrode Corporation
- [2] Andreyak, B. *Phase Shifted, Zero Voltage Transition Design Considerations and the UC3875 PWM Controller*, Texas Instruments Application Note SLUA107
- [3] Balogh, L. *The Current-Doubler Rectifier: An Alternative Rectification Technique For Push-Pull and Bridge Converters*, Texas Instruments Application Note SLUA121

## IMPORTANT NOTICE

Texas Instruments and its subsidiaries (TI) reserve the right to make changes to their products or to discontinue any product or service without notice, and advise customers to obtain the latest version of relevant information to verify, before placing orders, that information being relied on is current and complete. All products are sold subject to the terms and conditions of sale supplied at the time of order acknowledgment, including those pertaining to warranty, patent infringement, and limitation of liability.

TI warrants performance of its products to the specifications applicable at the time of sale in accordance with TI's standard warranty. Testing and other quality control techniques are utilized to the extent TI deems necessary to support this warranty. Specific testing of all parameters of each device is not necessarily performed, except those mandated by government requirements.

Customers are responsible for their applications using TI components.

In order to minimize risks associated with the customer's applications, adequate design and operating safeguards must be provided by the customer to minimize inherent or procedural hazards.

TI assumes no liability for applications assistance or customer product design. TI does not warrant or represent that any license, either express or implied, is granted under any patent right, copyright, mask work right, or other intellectual property right of TI covering or relating to any combination, machine, or process in which such products or services might be or are used. TI's publication of information regarding any third party's products or services does not constitute TI's approval, license, warranty or endorsement thereof.

Reproduction of information in TI data books or data sheets is permissible only if reproduction is without alteration and is accompanied by all associated warranties, conditions, limitations and notices. Representation or reproduction of this information with alteration voids all warranties provided for an associated TI product or service, is an unfair and deceptive business practice, and TI is not responsible nor liable for any such use.

Resale of TI's products or services with statements different from or beyond the parameters stated by TI for that product or service voids all express and any implied warranties for the associated TI product or service, is an unfair and deceptive business practice, and TI is not responsible nor liable for any such use.

Also see: [Standard Terms and Conditions of Sale for Semiconductor Products](http://www.ti.com/sc/docs/stdterms.htm). [www.ti.com/sc/docs/stdterms.htm](http://www.ti.com/sc/docs/stdterms.htm)

### Mailing Address:

Texas Instruments  
Post Office Box 655303  
Dallas, Texas 75265